



دانشگاه صنعتی اصفهان
دانشکده مکانیک

Crack Growth Resistance Curves

J integral and crack-growth resistance curves

Many materials with high toughness do not fail catastrophically at a particular value of J or $CTOD$. Rather, these materials display a rising R curve, where J and $CTOD$ increase with crack growth. In metals, a rising R curve is normally associated with the growth and coalescence of microvoids.

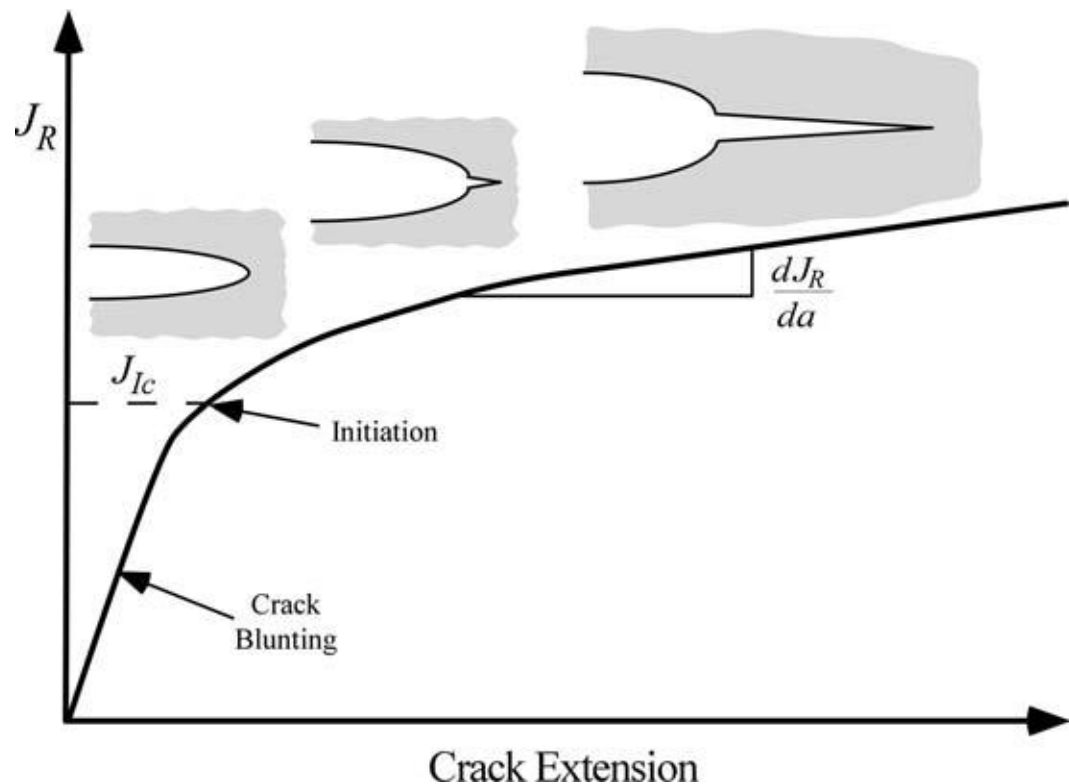

The commonly observed stages in ductile fracture are:

- Formation of a free surface at an inclusion or second-phase particle by either interface decohesion or particle cracking.
- Growth of the void around the particle by means of plastic strain and hydrostatic stress.
- Coalescence of the growing void with adjacent voids.

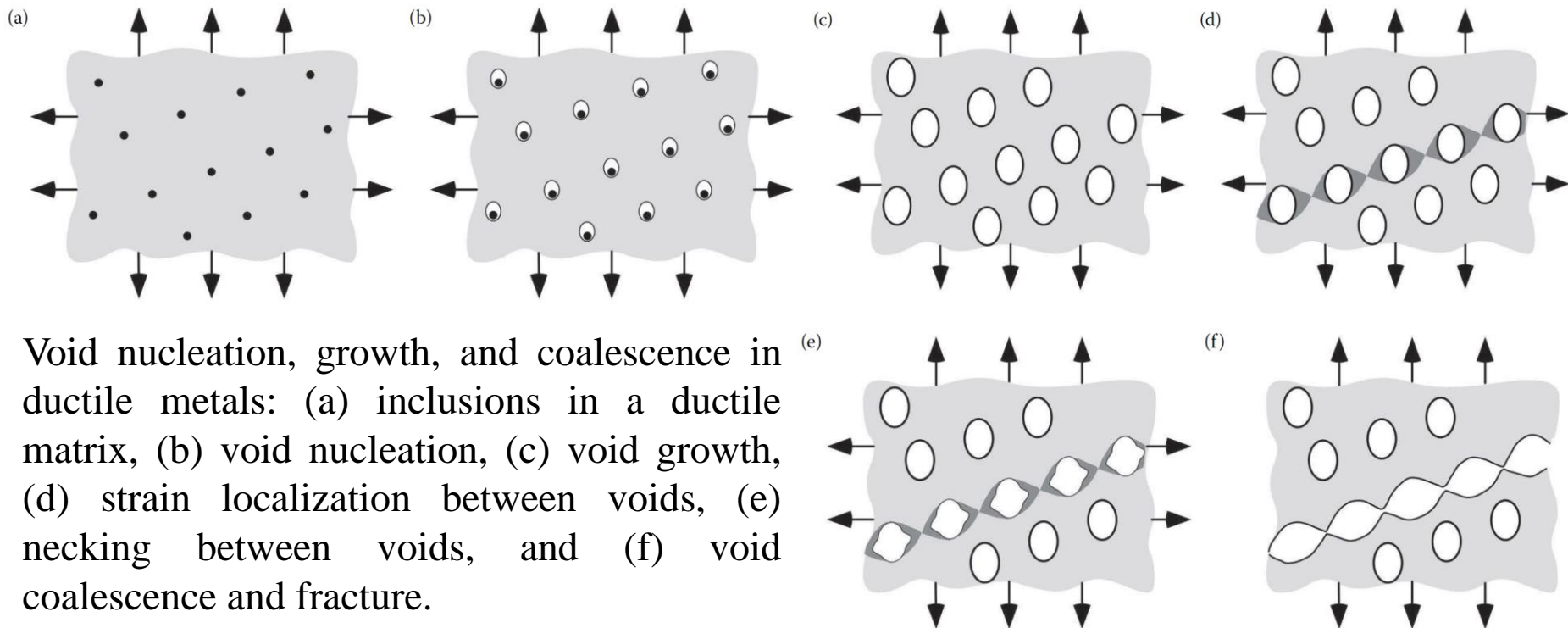

Void nucleation, growth, and coalescence in ductile metals: (a) inclusions in a ductile matrix, (b) void nucleation, (c) void growth, (d) strain localization between voids, (e) necking between voids, and (f) void coalescence and fracture.

Three stage of the ductile fracture process:

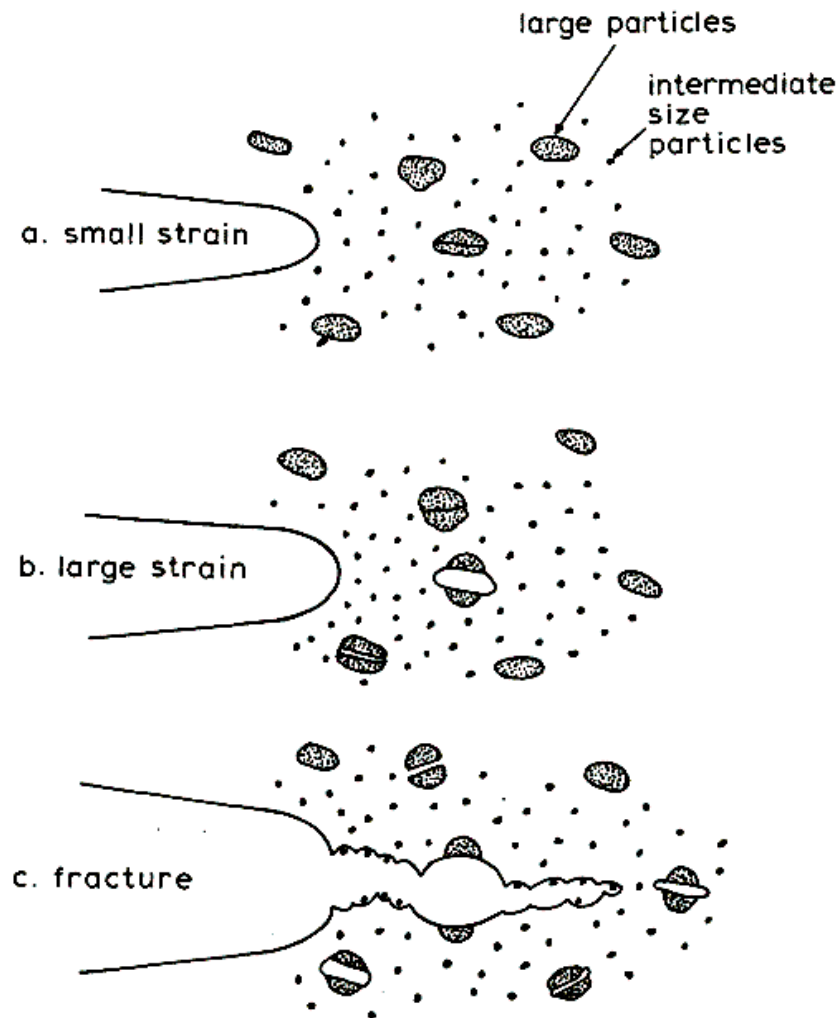

While initiation toughness provides some information about the fracture behavior of a ductile material, the entire R curve gives a more complete description. The slope of the R curve at a given amount of crack extension is indicative of the relative stability of the crack growth; a material with a steep R curve is less likely to experience unstable crack propagation. For J resistance curves, the slope is usually quantified by a dimensionless tearing modulus:

$$T_R = \frac{E}{\sigma_0^2} \frac{dJ_R}{da}$$

- **A**: R curve is nearly vertical:
 - small amount of apparent crack growth from blunting
- J_{Ic} : measure of ductile fracture toughness
- **Tearing modulus**

$$T_R = \frac{E}{\sigma_0^2} \frac{dJ_R}{da}$$

is a measure of crack stability

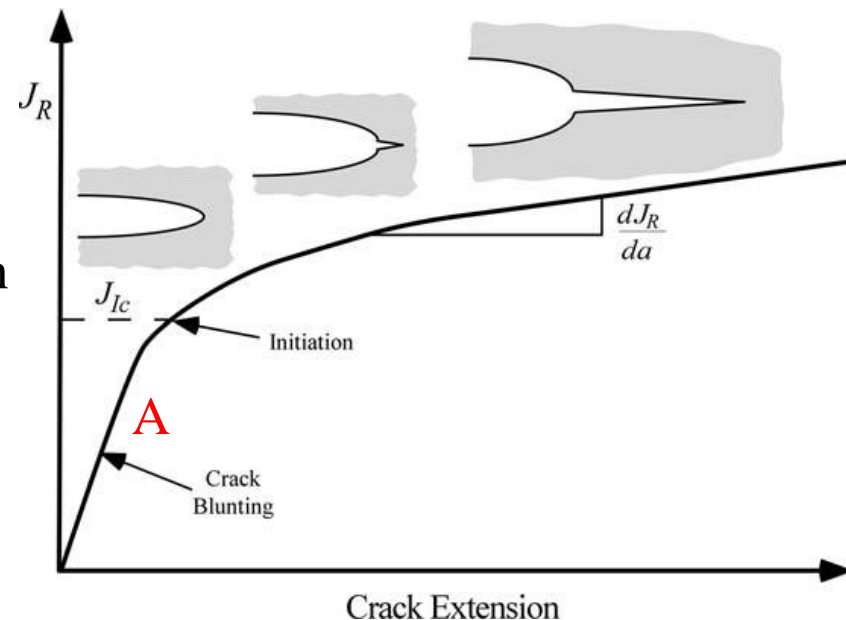

J-Controlled Crack Growth

(1) Crack Blunting

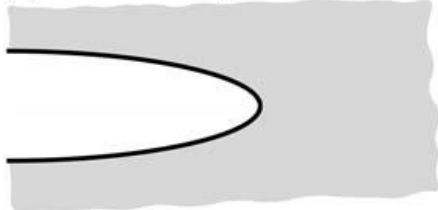

(2) Fracture Initiation

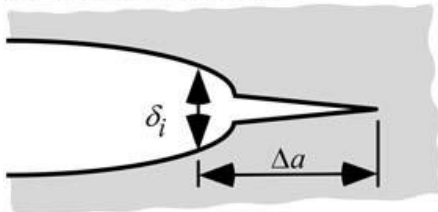

(3) Steady State Crack Growth

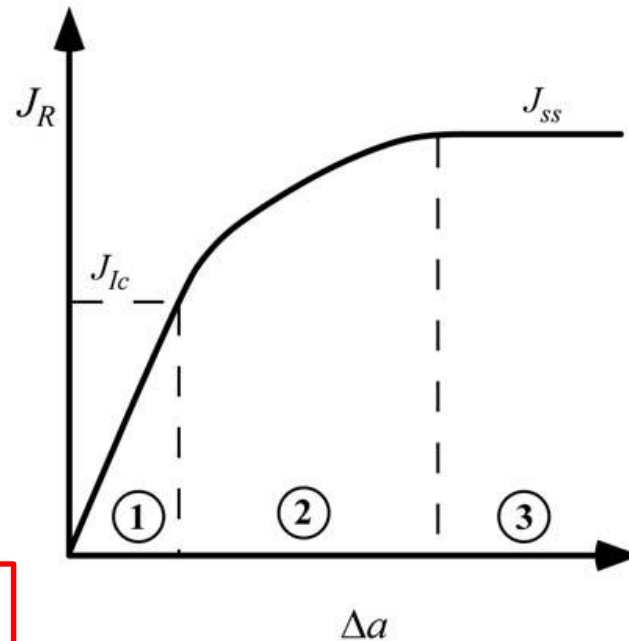
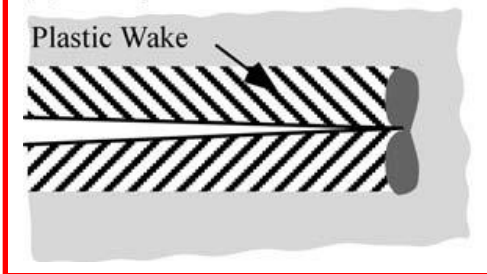

Rare in experiments because it requires large geometries!

Since the R curve slope has been represented by a dimensionless tearing modulus, it is convenient to express the driving force in terms of an *applied tearing modulus*:

$$T_{app} = \frac{E}{\sigma_0^2} \left(\frac{dJ}{da} \right)_{\Delta_T}$$

where Δ_T is the total remote displacement defined as

$$\Delta_T = \Delta + C_m P$$

and C_m is the system compliance

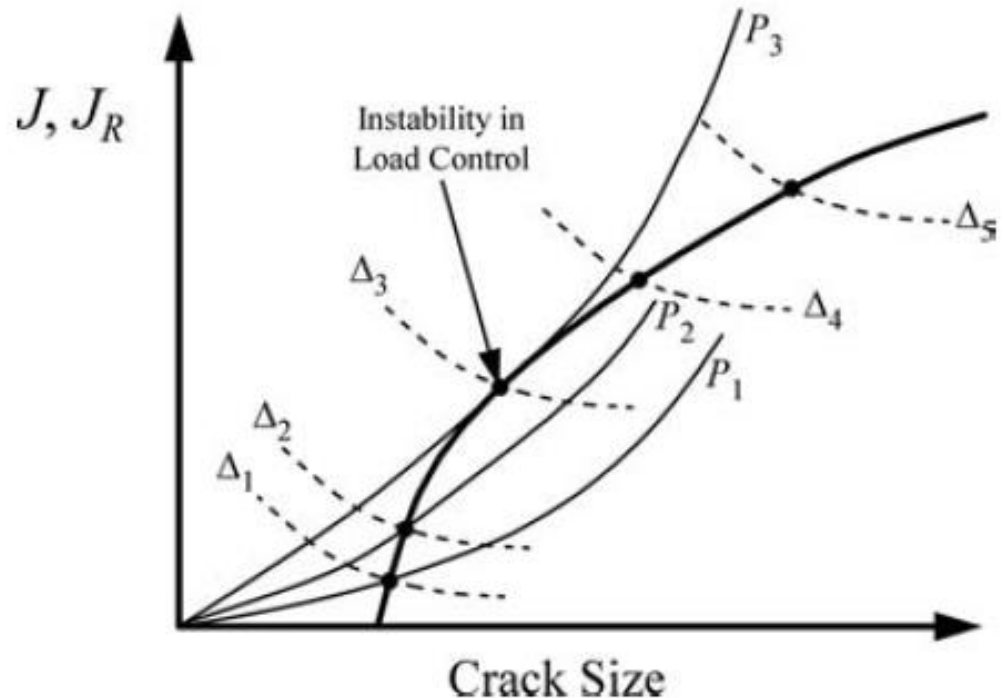

load control is usually less stable than displacement control

The figure schematically illustrates the general case of a cracked structure with finite system compliance, C_M . The structure is held at a fixed remote displacement, Δ_T given

$$\Delta_T = \Delta + C_M P$$

Differentiating the equation gives:

$$d\Delta_T = \left(\frac{\partial \Delta}{\partial a} \right)_P da + \left(\frac{\partial \Delta}{\partial P} \right)_a dP + C_M dP = 0$$

Assuming Δ (also the energy release rate) depends only on load and crack length:

$$dG = \left(\frac{\partial G}{\partial a} \right)_P da + \left(\frac{\partial G}{\partial P} \right)_a dP$$

$$\left(\frac{dG}{da} \right)_{\Delta_T} = \left(\frac{\partial G}{\partial a} \right)_P + \left(\frac{\partial G}{\partial P} \right)_a \left(\frac{dP}{da} \right)_{\Delta_T}$$

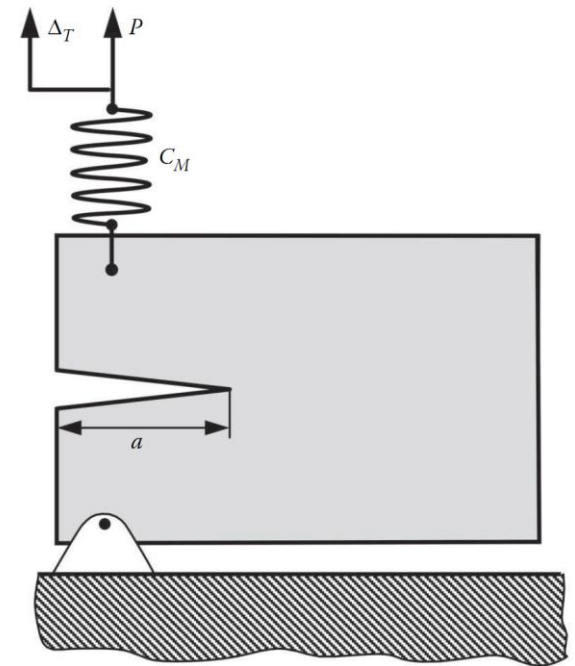

$$\left(\frac{dG}{da}\right)_{\Delta_T} = \left(\frac{\partial G}{\partial a}\right)_P - \left(\frac{\partial G}{\partial P}\right)_a \left(\frac{\partial \Delta}{\partial a}\right)_P \left[C_M + \left(\frac{\partial \Delta}{\partial P}\right)_a \right]^{-1}$$

Under dead-loading conditions, $C_M = \infty$, and all but the first term vanish. Conversely, $C_M = 0$ corresponds to an infinitely stiff system, and Equation * reduces to pure displacement control case.

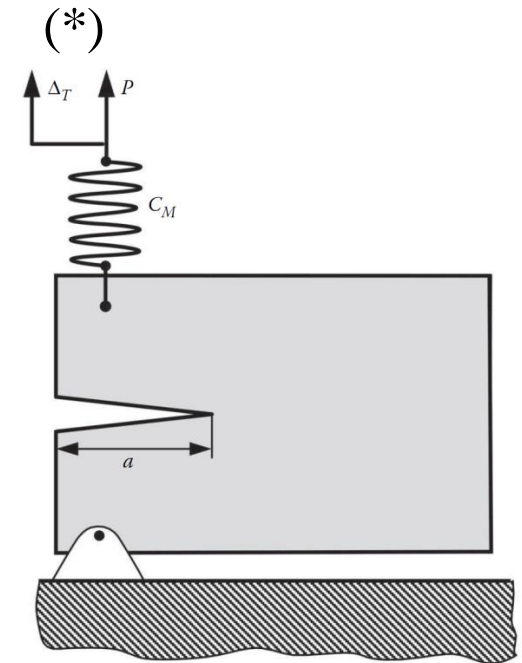

The slope of the driving force curve for a fixed ΔT is *identical* to the linear elastic case, except that **G** is replaced by **J**:

$$\left(\frac{dJ}{da}\right)_{\Delta T} = \left(\frac{\partial J}{\partial a}\right) - \left(\frac{\partial J}{\partial P}\right)_a \left(\frac{\partial \Delta}{\partial a}\right)_P \left[C_M + \left(\frac{\partial \Delta}{\partial P}\right)_a \right]^{-1}$$

For load control, $C_M = \infty$, and the second term in above equation vanishes:

$$\left(\frac{dJ}{da}\right)_{\Delta T} = \left(\frac{\partial J}{\partial a}\right)_P$$

For displacement control, $C_M = 0$, and $\Delta_T = \Delta$.

The conditions during stable crack growth can be expressed as follows:

$$J = J_R \quad T_{app} \leq T_R$$

Unstable crack propagation occurs when:

$$T_{app} > T_R$$

Example:

Derive an expression for the applied tearing modulus in the double cantilever beam (DCB) specimen with a spring in series, assuming linear elastic conditions.

Solution: From previous example, we have the following relationships:

$$J = G = \frac{P^2 a^2}{BEI} \quad \Delta = \frac{2Pa^3}{3EI}$$

$$\left(\frac{dJ}{da} \right)_P = \frac{2P^2 a}{BEI}$$

$$\left(\frac{\partial J}{\partial P} \right)_a = \frac{2Pa^2}{BEI}$$

$$\left(\frac{\partial \Delta}{\partial a} \right)_P = \frac{2Pa^2}{EI}$$

$$\left(\frac{\partial \Delta}{\partial P} \right)_a = \frac{2a^3}{3EI}$$

$$\left(\frac{dJ}{da} \right)_{\Delta_T} = \left(\frac{\partial J}{\partial a} \right) - \left(\frac{\partial J}{\partial P} \right)_a \left(\frac{\partial \Delta}{\partial a} \right)_P \left[C_M + \left(\frac{\partial \Delta}{\partial P} \right)_a \right]^{-1}$$



$$T_{app} = \frac{E}{\sigma_0^2} \left(\frac{dJ}{da} \right)_{\Delta_T}$$

$$T_{app} = \frac{2P^2 a}{\sigma_0^2 BI} \left\{ 1 - \frac{2a^3}{EI} \left[C_M + \frac{2a^3}{3EI} \right]^{-1} \right\}$$

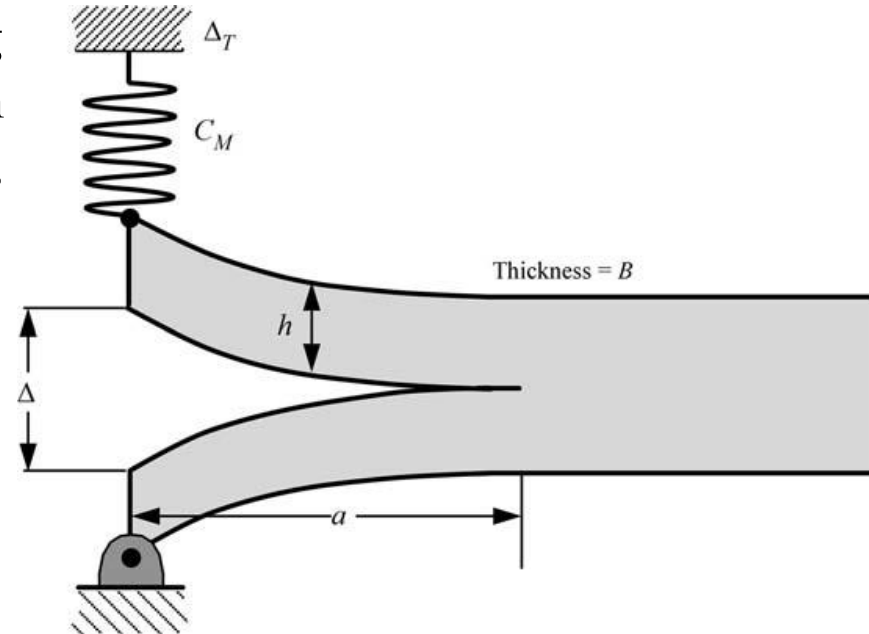

Fracture mechanics analyses based on J and CTOD become suspect when there is excessive plasticity or significant crack growth. In such cases, fracture toughness and the J-CTOD relationship depend on the size and geometry of the structure or test specimen.

small-scale yielding

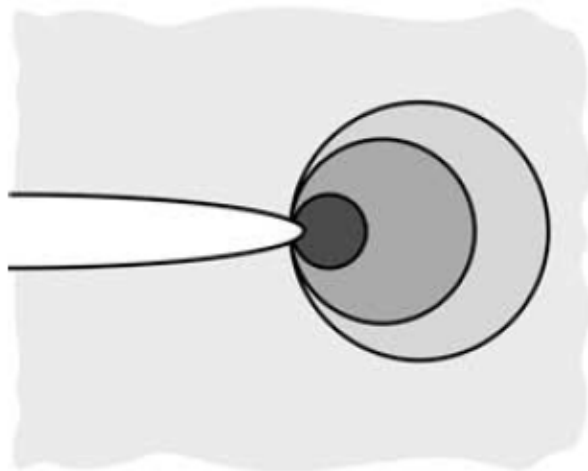

- Large Strain Region
- J-Dominated Zone
- K-Dominated Zone
- No Single-Parameter Characterization

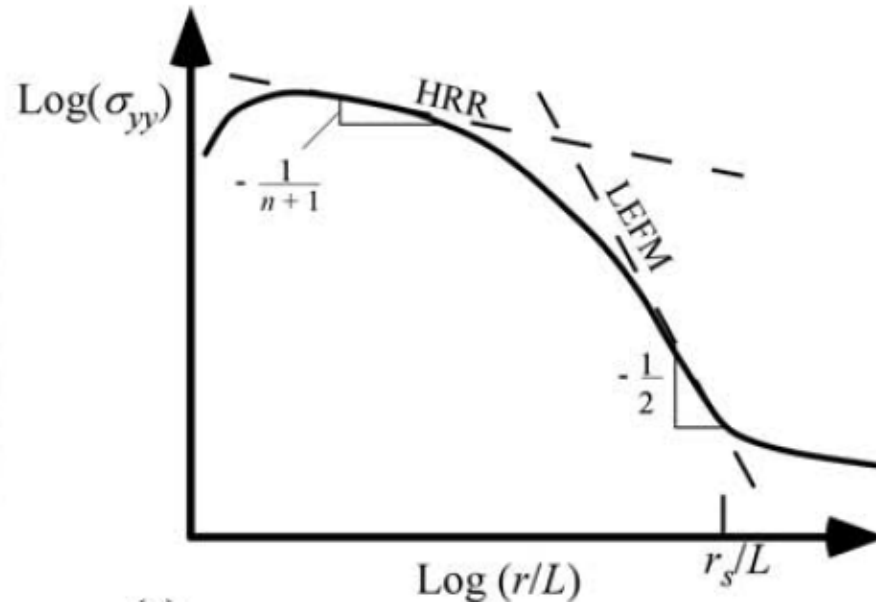

both K and J characterize crack tip conditions. At a short distance from the crack tip relative to L , the stress is proportional to $1/\sqrt{r}$; this area is called the K-dominated region. Inside of the plastic zone, the HRR solution is approximately valid.

Elastic-plastic conditions

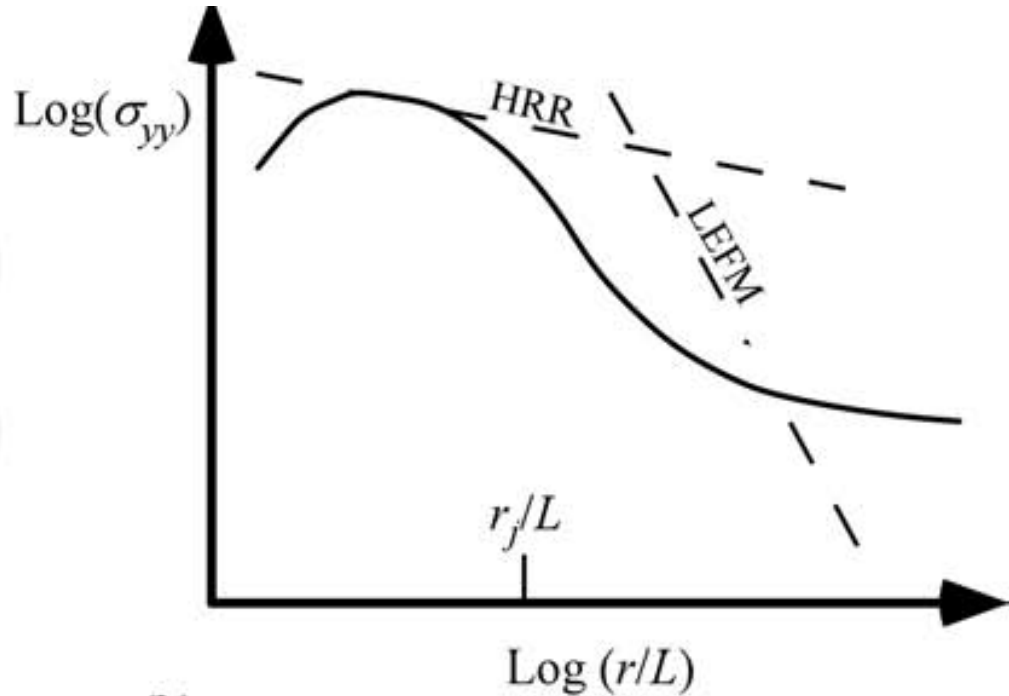
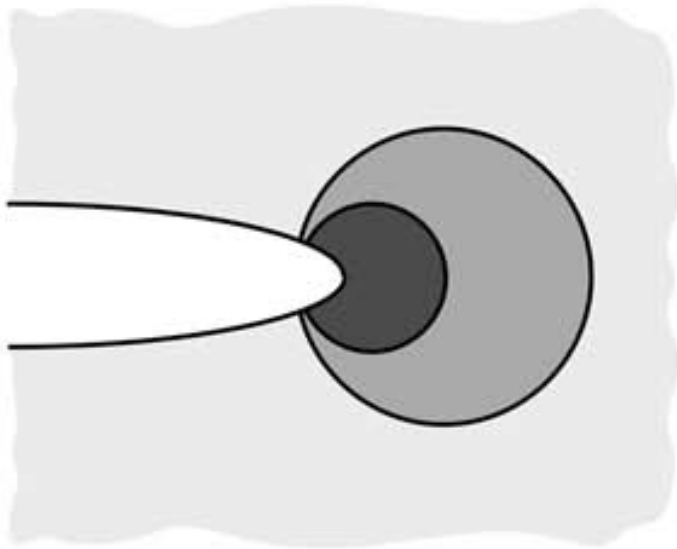

- Large Strain Region
- J-Dominated Zone
- K-Dominated Zone
- No Single-Parameter Characterization

The J is still approximately valid, but there is no longer a K field. As the plastic zone increases in size (relative to L), the K -dominated zone disappears, and the J integral is still an appropriate fracture criterion.

Large-scale yielding

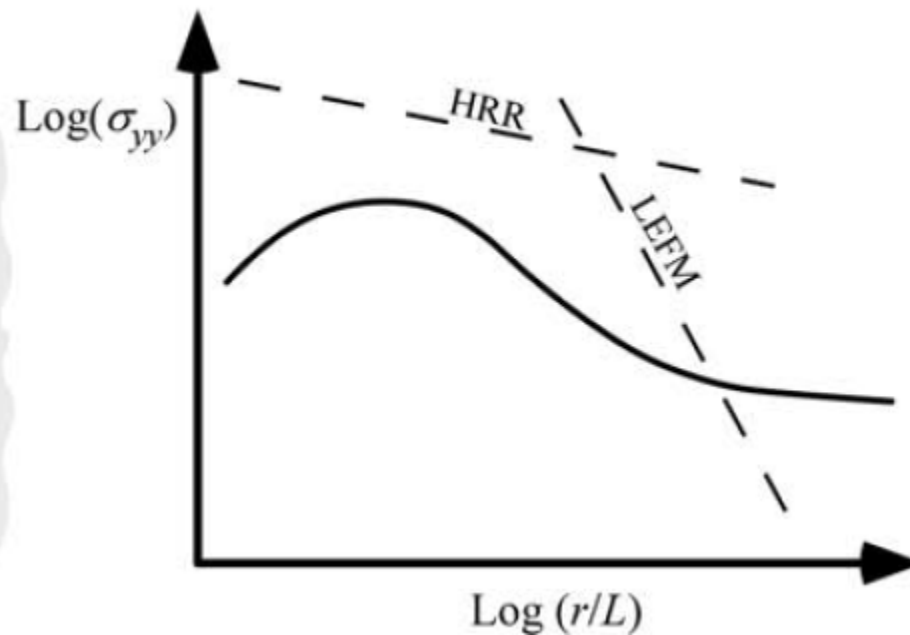
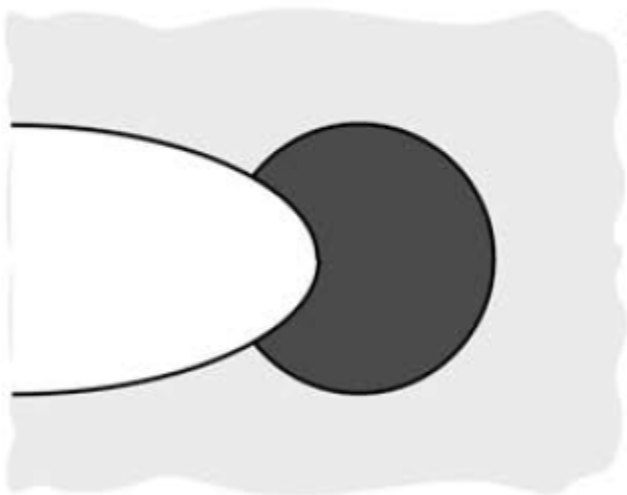

The size of the finite strain zone becomes significant relative to L , and there is no longer a region uniquely characterized by J . Single parameter fracture mechanics is invalid in large-scale yielding, and critical J values exhibit a size and geometry dependence.

J integral-controlled fracture

small-scale yielding

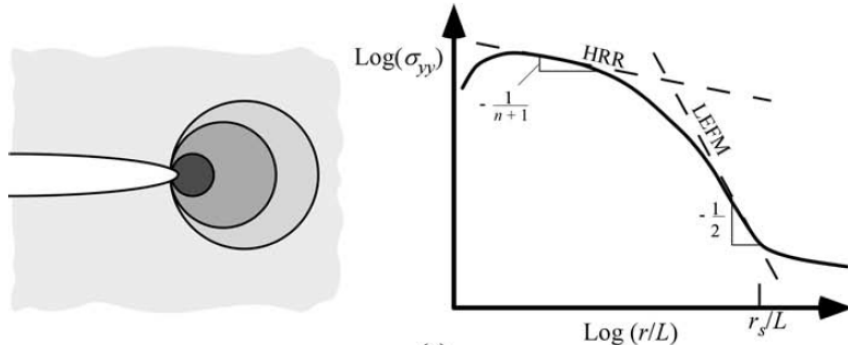

LEFM: small-scale yielding satisfied and generally have

$$\sigma_{eq} \ll \sigma_{YS}$$

Relevant parameters:

G (energy) K (stress)

Elastic-plastic conditions

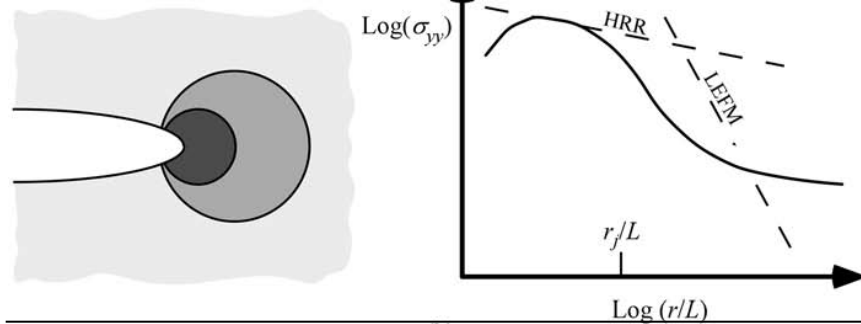

EPFM: small-scale yielding is gradually violated and

$$\sigma_{eq} \approx \sigma_{YS}$$

Relevant parameters:

J (energy & used for stress)

Large-scale yielding

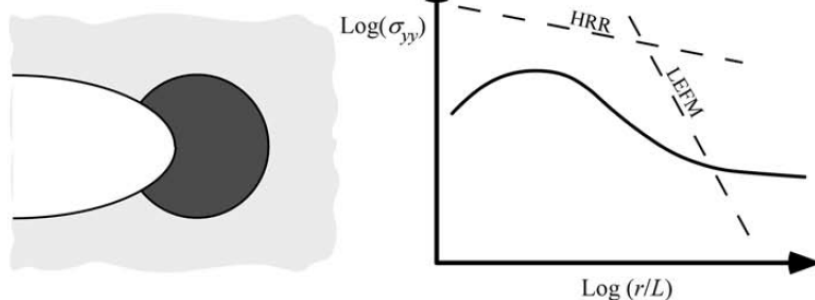

Large-scale yielding condition: No single parameter can characterize fracture!

J + other parameters (e.g. T stress, Q-J, etc)

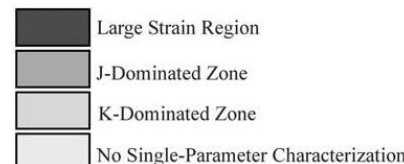

J-Controlled Crack Growth

The material directly in front of the crack violates the single-parameter assumption because the loading is highly nonproportional, i.e., the various stress components increase at different rates and some components actually decrease. In order for the crack growth to be J controlled, the elastic unloading and nonproportional plastic loading regions must be embedded within a zone of J dominance. When the crack grows out of the zone of J dominance, the measured R curve is no longer uniquely characterized by J.

In small-scale yielding, there is always a zone of J dominance because the crack-tip conditions are defined by the elastic stress intensity, which depends only on the current values of the load and crack size. The crack never grows out of the J-dominated zone as long as all the specimen boundaries are remote from the crack tip and the plastic zone.

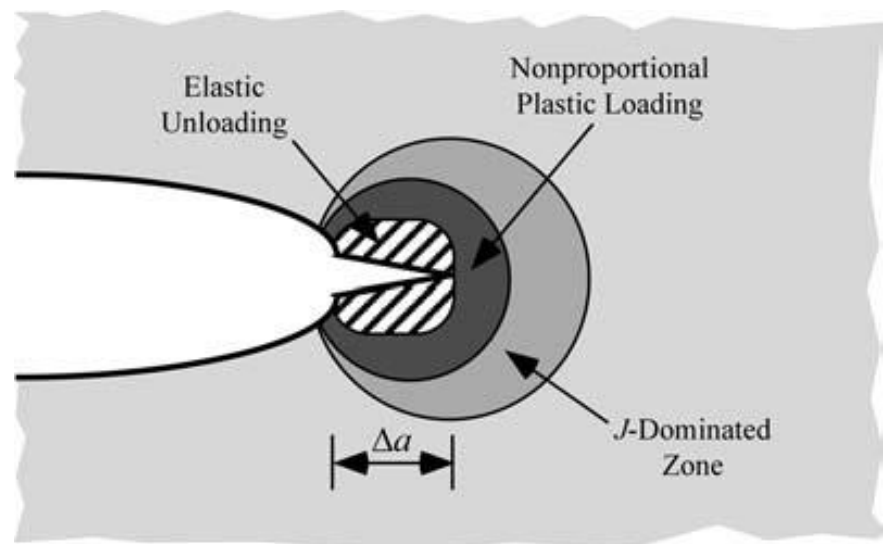

Crack Tip Constraint under Large-Scale Yielding

Actually, the plastic strain concentrations depend on the experiment which might be of the forms depicted in following pictures. It appears that the plastic zones are not reproducible from one test to another. Regarding the crack initiation criterion, we can say that the solution is no longer uniquely governed by J . The relation between J and δ_t is dependent on the configuration and on the loading. The critical J_C measured for an experiment might not be valid for another one. A two-parameter characterization is thus required.

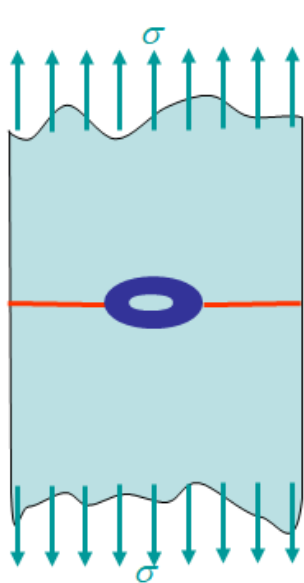

Large yielding: two side cracks subjected to uniform tension.

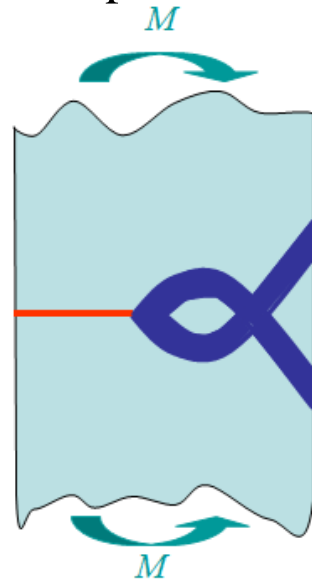

Large yielding: one side crack subjected to a bending moment.

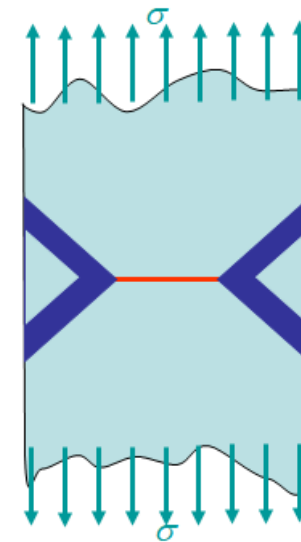

Large yielding: one inner crack subjected to uniform tension.